

INDUSTRIAL GASOLINE/LPG/NATURAL GAS ENGINE

KUBOTA WG SERIES (3-cylinder)

WG972-G/L/N-E4

RATED POWER

- 24.2kW @ 3600rpm(GASOLINE)
- 22.0kW @ 3600rpm(LPG)
- 20.4kW @ 3600rpm(NATURAL GAS)

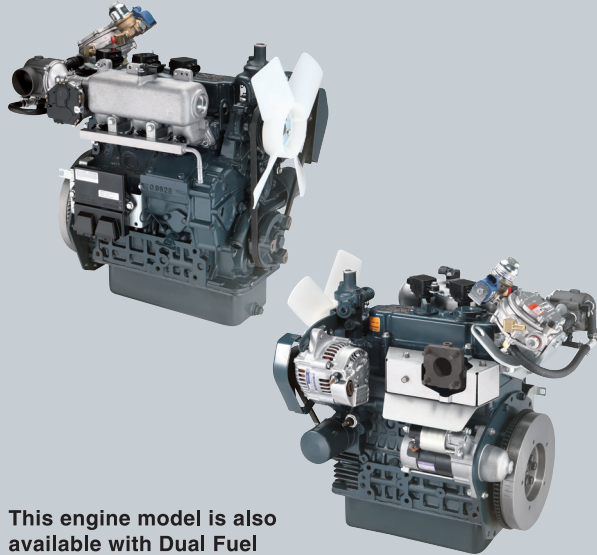

This engine model is also available with Dual Fuel (Gasoline and LPG).

Dual Fuel Version Shown.

PERFORMANCE CURVES

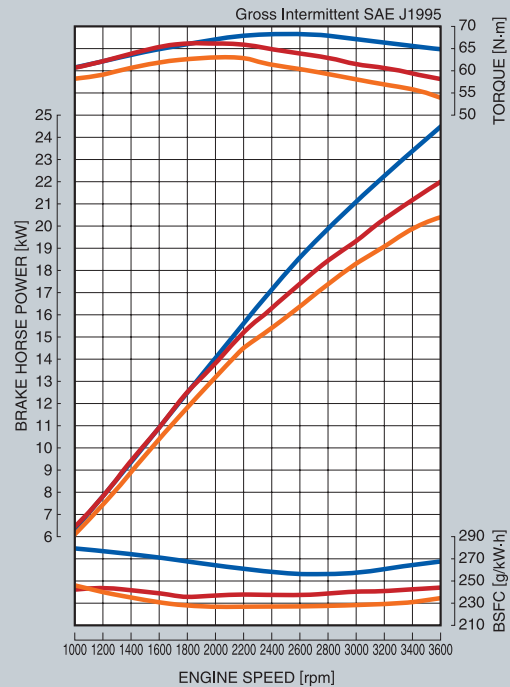

FEATURES and BENEFITS

Emission

Kubota's WG972-G / L / N-E4 engines have been designed to comply with the most stringent emission regulations: EPA Phase 3 and CARB Phase 4.

Fuel Flexibility

Installation compatibility between SI and CI engines is a good solution for customers who need fuel flexibility for their products. The Kubota WG972 has version of not only gasoline, LPG and natural gas but also dual fuel (Gasoline and LPG) version.

Durability and Reliability

Kubota's WG972 SI engines are designed after the Kubota Super Mini Series diesel (CI) engines, which are known worldwide as reliable industrial engines. The new WG972 engines offers very low vibration and is exceptionally quiet.

KUBOTA WG SERIES WG972-G/L/N-E4

GENERAL SPECIFICATIONS

Model		WG972-G-E4	WG972-L-E4	WG972-N-E4	
Emission Regulation		EPA Phase 3, CARB Phase 4			
Type		Vertical 4-cycle Liquid Cooled Engine			
		Gasoline use	LPG use	Natural gas use	
Number of Cylinders		3			
Bore	mm (in)	74.5 (2.93)			
Stroke	mm (in)	73.6 (2.90)			
Displacement	L (cu.in)	0.962 (58.68)			
Fuel		Unleaded gasoline	Commercial LPG	Natural gas	
Aspiration		Naturally Aspirated			
Rated Speed	rpm	3600			
Output: Gross Intermittent		kW	24.2	22.0	20.4
		HP	32.5	29.5	27.4
		ps	32.9	29.9	27.7
Direction of Rotation		Counter Clockwise viewed from flywheel			
Oil pan capacity	L (u.s.gal)	3.4 (0.90)			
Starter Capacity	V-kW	12-1.0			
Alternator Capacity	V-A	12-40			
Length	mm (in)	453 (17.8)	516 (20.3)	516 (20.3)	
Width	mm (in)	393 (15.4)			
Height	mm (in)	503 (19.8)			
Dry Weight	kg (lb)	74 (163.1)	77 (170.6)	77 (170.6)	

DIMENSIONS

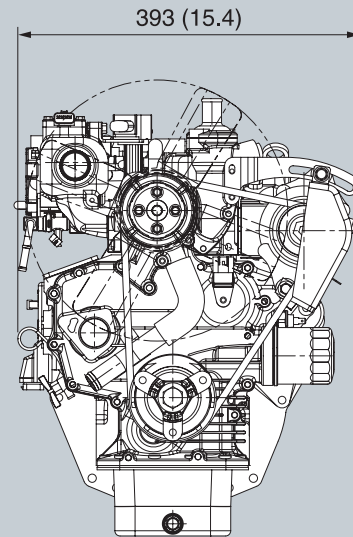
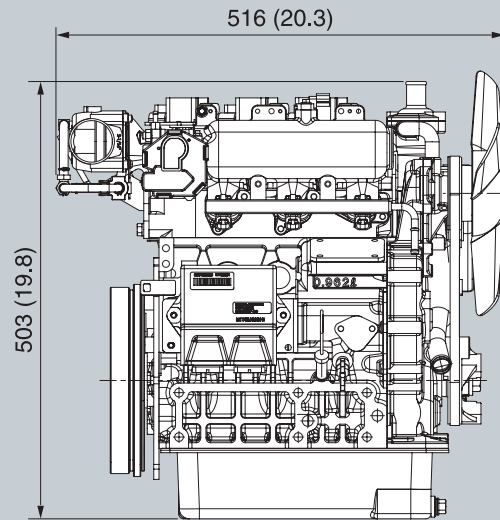

Dual Fuel Version Shown.
Dimensions and weight depend on composed specifications.

*Specification is subject to change without notice.
 *LPG: Commercial liquid propane gas only. Equivalent to propane HD-5 of GPA standard.
 *Natural gas: Commercial Compressed Natural Gas only.
 The performance shown is with Japanese standard CNG.
 *Output: Gross Intermittent SAE J1995
 *Dimensions and weight are according to Kubota's standard specifications.



KUBOTA Engine America Corporation

505 Schelton Road, Lincolnshire, IL 60069
 Phone: 847-955-2500 Fax: 847-955-2699
www.kubotaengine.com